



Communities of tree vegetation and wood-destroying fungi in parks of the Kyiv city, Ukraine

Olena Blinkova*, Oleksandra Ivanenko

Institute for Evolutionary Ecology NAS of Ukraine, 03143, Kyiv, 37 Lebedeva str., Ukraine

Abstract

Selected forestry parameters were investigated in the system of tree vegetation and wood-destroying fungi in parks of the Kyiv city along a gradient of recreational transformation. We investigated vitality, age structure and health conditions of woody plants (*Acer platanoides* L., *Aesculus hippocastanum* L., *Carpinus betulus* L., *Frangula alnus* Mill., *Pinus sylvestris* L., *Quercus robur* L., *Q. rubra* L., *Sambucus nigra* L., *Tilia cordata* Mill.), and species, systematic, trophic and spatial compositions of xylotrophic fungi (27 species of xylotrophs representing 22 genera, 16 families, 6 orders of divisions Basidiomycota; class Agaricomycetes). The results showed that the communities of tree vegetation and xylotrophic fungi in parks depend on the degree of recreational transformation of the environment. Vitality, age structure and health conditions of trees altered species composition of xylotrophs.

Key words: ecological links; parks; woody plants; xylotrophic fungi

Editor: Jaroslav Holuša

1. Introduction

Communities consisting of different biodiversity elements with their tight ecological links play a significant role in evolutionary ecology. In this context communities of tree vegetation and wood-destroying (xylotrophic) fungi are essential elements to study. These ecological objects represent an important basis for the modern indication and monitoring of the environment. Tree vegetation is an important element of forest ecosystems to preserve the landscape and especially biotic diversity of organisms.

Xylotrophic fungi are decomposers of organisms, and obligatory components of forest ecosystems. Wood-destroying fungi are essential functional elements of forest ecosystems, which are highly sensitive to environmental changes (Rypáček 1957; Stepanova & Mykhin 1979; Schmidt 2006; Yurchenko 2006; Terho et al. 2007; Dai et al. 2007; Schwarze 2008). In some cases, they are root and stem pathogens of trees, and hence, they negatively affect their health conditions. Numerous studies of the stated issues differ mostly in the methodological approaches and the depth of studies. The works often deal with only certain structural and functional components of forest ecosystems. They refer mostly to systematics and phytopathology of fungi. This leads to incomplete information, especially under the terms of biological objects being influenced by a complex of ecological factors of different origin, intensity and uncertainty.

The communities of tree vegetation and xylotrophic fungi as important bases for correct indication and monitoring the state of forest ecosystems, have not been sufficiently studied so far. This concerns the necessity of the complex analysis of evolutionarily established links between tree vegetation and xylotrophic fungi. The compositions of xylotrophic fungi and

tree vegetation reflect artificial phytocoenoses' development and state (Blinkova & Ivanenko 2014). In urban conditions of parks, which are not durable for anthropogenic or natural reasons, the resistance of tree vegetation to negative influence is significantly diminished and in general, the attrition of weakest plants and reformation of species composition and structures of parks increases (Terho et al. 2007; Schwarze 2008; Arefyev 2010; Glaeser & Smith 2010).

Due to the construction of park alleys, parkways, introduction of non-native crops and creation of new landscape components during the past decades, the parks in Kyiv have undergone an intensive recreational transformation, which is manifested in the break-down of structural and functional integrity of phytocoenoses' organisation. This in turn essentially affects the functioning of the communities of dominant woody species and xylotrophic fungi in urban ecosystems. It is also notable that there is no data on mycobiota of tree vegetation from the territory of the Kyiv parks. The literature survey and analyses of mycological collection of the National herbarium of Ukraine – Herbarium of M. G. Kholodny Institute of Botany NAS of Ukraine (KW-myc) showed that the investigation of wood-destroying fungi of Kyiv was localised in botanical gardens, in some objects of the nature reserve fund of Ukraine or natural landmarks. Fragmentary findings of xylotrophic fungi in artificial phytocoenoses were certified in herbarium: *Aurantiporus fissilis* (Berk. et M. A. Curtis) H. Jahn ex Ryvarden (as *Tyromyces fissilis* (Berk. et M. A. Curtis) Donk, KW 17867–17868; 1960), *Ganoderma lipsiense* (Batsch) G.F. Atk. (as *G. applanatum* (Pers.) Pat., KW 921; 1961), *Laetiporus sulphureus* (Bull.) Murrill (KW 17618, KW 17620; 1965, 1971), *Polyporus squamosus* (Huds.) Fr. (KW 18103; 1972) and *Trametes hirsuta* (Wulfen) Lloyd (KW 6; 1957).

*Corresponding author. Olena Blinková, e-mail: elena.blinkova@gmail.com, phone: +38 044 526 20 51

The hypothesis of our study is that the species, trophic, systematic and spatial compositions of xylotrophic fungi are closely associated with vitality, age structure and healths condition of stands in the Kyiv parks. The paper aim is to describe communities of tree vegetation and wood-destroying fungi of parks in urban conditions in relation to the level of recreational transformation of the environment.

2. Materials

2.1. Study site

The parks in the urban conditions of Kyiv were selected for the analyses since human impact is maximised in these objects. Kyiv is located on the right and left banks of the Dnipro river at the border between the Forest-Steppe zone and the Polissya of Ukraine following the geo-botanical division of Ukraine. The area of the city is 835.6 km², of which 43,600 ha are parks. The average annual temperature over the period 2013 – 2014 was 8.5 °C. The vegetation season (> 5 °C) lasted 204 days and started on April 10. The climate is of a semi-continental type for the Forest-Steppe zone. The geomorphologic structure of Kyiv belongs to 3 geomorphologic zones: South Polissya, Dnipro, Azov-Dnipro (Biluk 1977). Soddy-podzolic soils, gray forest soils and sod meadow soils are the main soil types in Kyiv (Gavruluk

1956). Kyiv is located at the border of two geobotanical zones: European broad-leaved forests, represented by the sub-province of mixed coniferous-broad-leaved forests of Polissya, and the European steppe region, represented by the Ukrainian forest-steppe sub-province of oak forests, steppified meadows and meadow steppes (Biluk 1977).

In the survey conducted in September 15 – 30, 2014 we distinguished seven parks in the Kyiv city (Table 1).

2.2. Method

Within each studied park, the mapping of dominant tree vegetation was carried out at experimental plots EP1–EP7. The experimental plots represent the parks and were chosen by the reconnaissance method. Each experimental plot was established according to the detailed route-method (Dilis 1974; Vasilevich 1992; Mirkin 1998). The area of each experimental plot was 0.5 – 0.7 ha (Dilis 1974).

By taking into account basic characteristics of recreational changes of elements of structural and functional organisation of parks in Kyiv (the state of tree stratum, undergrowth, soil surface layer, herbaceous cover and leaf-litter) the level of recreational transformation rate was specified for each experimental plot ng from minimal to maximal consequences. The stages of the recreational transformation were assessed according to Rusin (2003) (Table 2).

Table 1. General characteristics of studied parks.

No	Name	GPS coordinates	Year Established	Affiliation to the nature reserve fund	Area [ha]	Dominant tree vegetation
1	Park “Syrets'kyi hay”	50°28'30” N, 30°25'30” E	1952	monument of landscape art of national significance	176,1	<i>Quercus robur</i> L., <i>Carpinus betulus</i> L., <i>Acer platanoides</i> L., <i>Tilia cordata</i> Mill., <i>Betula pendula</i> Roth, <i>Populus alba</i> L.
2	Holosshyivs'kyi Park name Maksyma Ryl's'koho	50°38'25” N, 30°50'12” E	1957	monument of landscape art of local significance	140,9	<i>Quercus robur</i> L., <i>Carpinus betulus</i> L., <i>Acer platanoides</i> L.
3	Park “Peremoha”	50°46'31” N, 30°60'56” E	1965	—	66,1	<i>Quercus robur</i> L., <i>Pinus sylvestris</i> L., <i>Fraxinus excelsior</i> L.
4	Park-monument of landscape art “Nivyky”	50°46'37” N, 30°42'82” E	1972	monument of landscape art of local significance	55,1	<i>Acer platanoides</i> L., <i>Acer saccharinum</i> L., <i>Quercus robur</i> L., <i>Aesculus hippocastanum</i> L., <i>Ulmus glabra</i> Huds., <i>Thuja occidentalis</i> L., <i>Morus alba</i> L.
5	Park “Druzhby narodiv”	50°30'15” N, 30°32'35” E	1972	—	219,4	<i>Aesculus hippocastanum</i> L., <i>Acer platanoides</i> L., <i>A. tataricum</i> L., <i>Quercus rubra</i> L., <i>Tilia cordata</i> Mill., <i>Picea abies</i> [L.] H. Karst., <i>Salix alba</i> L.
6	Solom'yanskyi Landscape Park	50°42'55” N, 30°48'45” E	1973	—	29,6	<i>Quercus robur</i> L., <i>Q. rubra</i> L., <i>Tilia cordata</i> Mill., <i>Acer platanoides</i> L., <i>Fraxinus excelsior</i> L.
7	Forest Park “Urochyshe Sovky”	50°44'09” N, 30°37'42” E	1976	—	35,3	<i>Quercus robur</i> L., <i>Q. rubra</i> L., <i>Pinus sylvestris</i> L., <i>Betula pendula</i> Roth

Table 2. Stages of recreational transformation.

Degradation stage	State of		
	Herbaceous cover and leaf-litter	Tree stratum and undergrowth	Soil surface
1	full species composition of herbaceous plant community, plant projective cover is 90 – 100%, leaf-litter is not broken	trees are healthy, undergrowth is numerous and of different ages	I stage of degradation
2	appearance of ruderal or meadow herbaceous species, projective cover is 80 – 90%, leaf-litter begins to trample down	trees are weakened, undergrowth is numerous but not of different ages	II stage of degradation
3	share of ruderal or meadow herbaceous species is 5 – 10%, projective cover is 70 – 80%, leaf-litter is trampled down	trees are weakened or heavily weakened, undergrowth is limited	III stage of degradation
4	share of ruderal or meadow herbaceous species is 10 – 20%, projective cover is 50 – 70%, leaf-litter begins to deteriorate	trees are heavily weakened, low viability of undergrowth is located clumps	IV stage of degradation
5	ruderal or meadow herbaceous species are dominant species, projective cover is 0 – 50%, leaf-litter is completely absent	trees are heavily weakened or wilting with significant mechanical damage, undergrowth is absent	V stage of degradation

2.2.1 Assessment of tree health conditions and vitality structure

Tree health condition (category of tree state) was assessed in accordance with the Sanitary Forest Regulation of Ukraine (1995). The stand state index was calculated as a sum of the values of the tree state index of the trees in a certain category, divided by the total number of the examined trees:

$$I_c = \frac{\sum k_i \cdot n_i}{N} \quad [1]$$

k_i – category of tree state (I–VI); n_i – number of trees certain category of tree state; N – total number of trees.

The stands with the index values from the interval 1 – 1.5 are considered healthy (I), the weakened ones (II) have the values 1.51 – 2.50, heavily weakened (III) – 2.51 – 3.50, the wilting ones (IV) – 3.51 – 4.50, recently dead (V) – 4.51 – 5.50, old dead stands (VI) – 5.51 – 6.50.

In order to avoid the influence of the irregular intensity of silvicultural practice upon the index of stand state, the weighted average of Kraft classes (WAKC; vitality of tree vegetation) was calculated for each state category as a sum of the number of trees in each Kraft class multiplied by the stand state index (I – V), and divided by the total number trees in a certain state category:

$$WAKC = \frac{\sum k_{kc} \cdot I_c}{n_i} \quad [2]$$

k_{kc} – number of trees in each Kraft class; I_c – stand state index; n_i – number of trees in a certain state category.

For this purpose, the trees in each category were divided into 5 Kraft classes. Classes V^a and V^b were combined into class V, since the trees of these categories were rarely found in the experimental plots. The WAKC depicts the damage zone in the tree stratum: the closer the WAKC is to I Kraft class, the higher is the degree of damage.

For each stand, forest mensuration parameters were derived: age (I); weighted average of diameters (D_{ave}), height (H_{ave}), diameter and height range ($D_{min} - D_{max}$; $H_{min} - H_{max}$) and standard deviation (S.D.), stand density (N), stand basal area as a sum of tree basal areas (G_n). The morpho-metric parameters were measured by an optical altimeter of Suunto PM-5 and Waldmeister 100alu callipers. Mechanically damaged woody plants were the trees and bushes with cutliving branches, injuries on the stem reaching cambium.

2.2.2 Soil surface layer assessment

The state of the soil surface layer was evaluated using the following categories of disturbance: 1 – undisturbed soil; 2 – weakened mulch (single passes); 3 – footpath in mulch; 4 – footpath or road without mulch; 5 – footpath or road with washaways; 6 – deposition and washaways made by recreants descending steep slopes. The degradation stages of soil surface layer were defined as follows: I – the 3rd, 4th, 5th and 6th categories of disturbance cover not more than 2% of the area of an experimental plot; II – from 2% to 10% of the plot area; III – from 10% to 25% of the area; IV – from 26% to 40% of the

area; V – over 40% of the plot area (Polyakov 2009). Clogging of the soil's surface by solid waste was defined as the share clogged area from the total area of the experimental plot.

2.2.3 Herbaceous cover assessment

The taxa nomenclature was adopted from Cherepanov (1981) while taking into account the existing “International Code of Nomenclature for algae, fungi, and plants” (2011). We determined the species composition and the total projective cover of dominant herbaceous plants.

2.2.4 Data collection and determination of fungi

The ecological research was performed in each experimental plot at different diagnostic levels of xylotrophic fungal existence: organ, tree, population (species), biogroup (stratum) of phytocoenosis, phytocoenosis. According to Arefyev (2010), the measuring unit is a host tree, on which carpophores of certain fungi species were detected. The collection of factual evidence was carried out during the period of the visible growth and the formation of carpophores of xylotrophic fungi in the vegetation period. Every detected species was photographed in vivo by Nikon Coolpix L830 digital camera. The species that were easily identified “in oculo nudo” and did not require additional micro-morphological studies were not included in exsiccates. If required, the colour, smell, structure of carpophores were noted including the reaction of carpophores to mechanical damage (change of colour, sap ooze) and the substrate. The determination of fungi species was based on the methods of Eriksson et al. (1973 – 1988), Bondarceva & Parmasto (1986), Cléménçon (2009), Bernicchia & Gorjón (2010) and Yurchenko (2010). The scientific names of fungi and their macrosystems are according to CORTBASE v. 2.1 (Parmasto et al. 2009) and MycoBank (Robert et al. 2005). Author's names of fungi species are according to Kirk & Ansell (1992).

2.2.5 Assessment of trophic and spatial compositions of fungi

The analysis of the trophic composition of fungi communities was based on the distribution of wood-destroying fungi on trees. We distinguished four trophic groups of xylo-trophes: eurytrophes of I rank (communities of coniferous and deciduous trees), eurytrophes of II rank on coniferous trees, eurytrophes of II rank on deciduous trees and stenotrophes (communities composed of only one genus of woody plants). The dead substrate of the host trees of xylotrophic fungi was divided into three categories – deadwood, fallen wood (branches and stems) and stumps depending on the morpho-metric parameters. The analysis of the spatial composition of the communities of wood-destroying fungi was based on the distribution of wood-destroying fungi in myco-horizons: root, ground, stem base, stem and photosynthesising myco-horizons (Fig. 1).

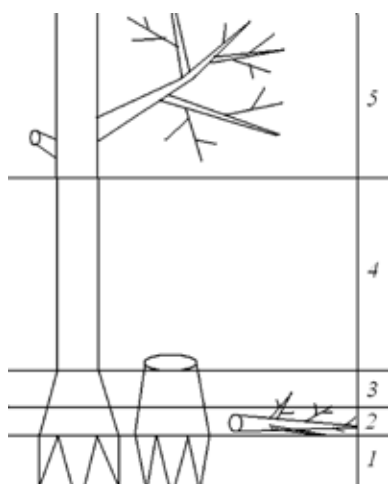

Fig. 1. Specification of myco-horizons: 1 – root, 2 – ground, 3 – stem base, 4 – stem, 5 – photosynthesising myco-horizons.

2.2.6 Statistical analyses

Menhinik's Index was used to determine the species richness of wood-destroying fungi:

$$D_{Mn} = \frac{S}{\sqrt{N}} \quad [3]$$

S – number of species; N – number of findings.

Shannon's Index of diversity was used for the generalised assessment of wood destroying fungi diversity:

$$H = \sum p_i \log_{10} p_i \quad [4]$$

p_i – relative proportion of each species.

Pielou's Index was used for the generalised assessment of wood destroying fungi:

$$E_{pi} = \frac{H}{H_{max}} \quad [5]$$

H – value of Shannon's Index of diversity, $H_{max} = \lg N$, $\lg N$ – number of wood-destroying fungi species (Schmidt 1980).

The similarity of the formed associations "tree-wood-destroying fungi" was studied by cluster analysis (OriginPro 9) using the weighted average of quantitative and qualitative indicators of the investigated trees (vitality, age structure and health condition) and fungi (species, systematic, trophic and spatial composition) at each experimental plot. The standardised Euclidean distance was selected for the assessment of the distance. The detection of the diagnostic indicators for the assessment of the associations between tree vegetation and wood-destroying fungi along the gradient of recreational transformation in urban conditions of Kyiv was performed by the principal components analysis in order to reduce and interpret data sets with underlying linear structures (OriginPro 9).

3. Results

3.1 Assessment of the recreational transformation of city parks

The level of the recreational transformation of the city parks was determined. The studied parks were ranked on the base of the human impact and the stages of recreational transformation of territory (Fig. 2) from minimum to maximum degradation as follows: 1 – Park "Druzhby narodiv", 2 – Park "Peremoha", 3 – Holosshyivs'kyk Park name Maksyma Ryl's'koho, 4 – Park "Syrets'kyk hay", 5 – Solom'yanskyk Landscape Park, 6 – Forest Park "Urochyshe Sovky", 7 – Park-monument of landscape art "Nyvky".



Fig. 2. Location of study areas in Kyiv: 1 – Park "Druzhby narodiv", 2 – Park "Peremoha", 3 – Holosshyivs'kyk Park of Maksyma Ryl's'koho, 4 – Park "Syrets'kyk hay", 5 – Solom'yanskyk Landscape Park, 6 – Forest Park "Urochyshe Sovky", 7 – Park-monument of landscape art "Nyvky".

3.2. Summary results of mycological survey

Our mycological study detected altogether 27 species of macromycetes (166 findings of xylotrophic fungi), 22 genera, 16 families, 6 orders of Basidiomycota division (class Agaricomycetes) at all experimental plots together (Appendix 1). In general, 693 individuals (9 species) of woody plants were studied.

3.3. In-depth assessment of the city parks

3.3.1 Park "Druzhby narodiv"

The territory of the "Druzhby narodiv" park has the fewest signs of the recreational transformation of parks in Kyiv. EP1 (0.5 ha) was located on the island Muromets between the left and right banks of the river Dnipro. The stand was two-storeyed; the canopy cover was 0.7 – 0.8. The first storey was composed of *Acer platanoides* L. ($A = 40 - 60$; $G_n = 54.3 \text{ m}^2 \text{ ha}^{-1}$; $N = 145 \text{ psc. ha}^{-1}$; $H_{ave} = 14.9 \text{ m}$, $H_{min} = 13.7 \text{ m}$, $H_{max} = 16.7 \text{ m}$, S.D. = 1.45 m; $D_{ave} = 31.5 \text{ cm}$; $D_{min} = 22.1 \text{ cm}$, $D_{max} = 38.3 \text{ cm}$, S.D. = 5.25 cm), *Tilia cordata* Mill.

($I = 1.79$; $A = 40 - 60$; $G_n = 47.1 \text{ m}^2 \text{ ha}^{-1}$; $N = 78 \text{ psc. ha}^{-1}$; $H_{\text{ave}} = 14.6 \text{ m}$, $H_{\text{min}} = 12.9 \text{ m}$, $H_{\text{max}} = 16.1 \text{ m}$, $S.D. = 1.32 \text{ m}$; $D_{\text{ave}} = 29.7 \text{ cm}$; $D_{\text{min}} = 20.7 \text{ cm}$, $D_{\text{max}} = 35.1 \text{ cm}$, $S.D. = 6.82 \text{ cm}$). The second storey was composed *Aesculus hippocastanum* L. ($A = 20 - 40$; $G_n = 12.3 \text{ m}^2 \text{ ha}^{-1}$; $N = 25 \text{ psc. ha}^{-1}$; $H_{\text{ave}} = 10.4 \text{ m}$, $H_{\text{min}} = 8.7 \text{ m}$, $H_{\text{max}} = 12.9 \text{ m}$, $S.D. = 1.56 \text{ m}$; $D_{\text{ave}} = 19.2 \text{ cm}$; $D_{\text{min}} = 15.3 \text{ cm}$, $D_{\text{max}} = 24.9 \text{ cm}$, $S.D. = 5.95 \text{ cm}$). Mechanically damaged trees were not recorded.

The projected cover of the herbaceous storey was 94.5%. *Chelidonium majus* L., *Ballota nigra* L., *Impatiens parviflora* L., *Stenactis annua* L., *Trifolium repens* L. dominated. The soil surface was in I stage of degradation: damaged areas occupied 1.9% of the total area, while 3rd, 4th, 5th and 6th were not detected. The clogging of the soil's surface was 0.01 – 0.03%. The overall stage of the recreational transformation was I.

At EP1 we detected 4 species of xylophages that represented 3 genera, 3 families, 2 orders on *Tilia cordata* Mill. and *Aesculus hippocastanum* L. 75% findings of xylophagous fungi were eurytrophes of II rank on deciduous trees: *Fomes fomentarius* (L.) Fr., *Peniophora cinerea* (Pers.) Cooke and *Stereum hirsutum* (Willd.) Pers. Stenotrophes (25.0% of findings) were represented by only one species: *Peniophora rufomarginata* (Pers.) Bourdot et Galzin (Appendix 1). The shares of xylophagous fungi in different substrate categories showed that all species were developed on trees of I – IV state categories.

The analysis of the vitality and health conditions of *Acer platanoides* L. revealed the absence of pathological processes: 67.1% of trees were healthy ($I = 1.47$), 25.3% were weakened ($I = 2.34$), and 7.6% were heavily weakened ($I = 3.05$). WAKC of healthy trees of *Acer platanoides* L. was 1.45 – 1.55. The analysis of the health conditions of *Tilia cordata* Mill. showed similar results as for *Acer platanoides* L.: 72.4% of trees were healthy ($I = 1.40$), 20.7% were weakened ($I = 1.75$), and 6.9% were heavily weakened ($I = 2.77$). WAKC of healthy trees of *Tilia cordata* Mill. was 1.40 – 1.45. 60.0% findings of *Peniophora rufomarginata* (Pers.) Bourdot et Galzin was observed on *Tilia cordata* Mill. of III state category, I Kraft class. The analysis of the vitality (WAKC of healthy trees = 2.55 – 2.60) and health conditions ($I = 1.51$) of *Aesculus hippocastanum* L. revealed a small degree of damage and the absence of pathological processes in the system. 80.0% of findings of fungi (*Fomes fomentarius* (L.) Fr., *Peniophora cinerea* (Pers.) Cooke and *Stereum hirsutum* (Willd.) Pers.) occurred on heavily weakened trees (IV – V Kraft classes) of *Aesculus hippocastanum* L. ($I = 3.15$) in the photosynthesising myco-horizon (75.0%) and stem base myco-horizon (25.0%) (Appendix 2). We also observed *Peniophora cinerea* (Pers.) Cooke on fallen wood (branches, $D_{\text{ave}} = 1.7 \text{ cm}$) of *Quercus rubra* L. (I Kraft class, II category of stand state).

3.3.2 Park “Peremoga”

EP2 (0.5 ha) was located in the Park “Peremoga” on the left bank of the river Dnipro. The stand was two-storeyed; the canopy cover 0.6 – 0.7. The first storey composed of *Pinus sylvestris* L. ($A = 40 - 60$), which had following stand inventory parameters: $G_n = 108.1 \text{ m}^2 \text{ ha}^{-1}$; $N = 205 \text{ psc. ha}^{-1}$;

$H_{\text{ave}} = 17.6 \text{ m}$, $H_{\text{min}} = 15.7 \text{ m}$, $H_{\text{max}} = 20.7 \text{ m}$, $S.D. = 1.45 \text{ m}$; $D_{\text{ave}} = 31.5 \text{ cm}$; $D_{\text{min}} = 22.1 \text{ cm}$, $D_{\text{max}} = 38.3 \text{ cm}$, $S.D. = 5.25 \text{ cm}$. The second storey composed *Quercus robur* L. ($A = 40 - 60$). Stand parameters of *Quercus robur* L.: $G_n = 95.3 \text{ m}^2 \text{ ha}^{-1}$; $N = 107 \text{ psc. ha}^{-1}$; $H_{\text{ave}} = 15.3 \text{ m}$, $H_{\text{min}} = 12.2 \text{ m}$, $H_{\text{max}} = 18.4 \text{ m}$, $S.D. = 2.08 \text{ m}$; $D_{\text{ave}} = 24.2 \text{ cm}$; $D_{\text{min}} = 19.2 \text{ cm}$, $D_{\text{max}} = 28.8 \text{ cm}$, $S.D. = 3.48 \text{ cm}$. Mechanically damaged trees (2.2%, an average area of 53.2 cm²) were observed at one place where fire occurred.

The projected cover of the herbaceous storey was 80.5%. The dominant species were *Achillea millefolium* L., *Artemisia vulgaris* L., *Calamagrostis epigeios* (L.) Roth., *Centaurea marschalliana* Spreng., *Lolium perenne* L., *Poa nemoralis* L., *Polygonum aviculare* L. and others. The leaf-litter has begun to be trampled down by people. Overall, the soil surface was in II stage of degradation: damaged areas occupied 9.1% out of which 5.3% were in 3rd, 4th, and 5th categories of soil surface degradation. The clogging of the soil's surface was 0.01 – 0.03%, similarly as at EP1. The park was assigned II stage of the recreational transformation.

We detected 3 species of xylophages presented by 3 genera, 3 families, 3 orders. 100% findings of xylophagous fungi were eurytrophes of II rank on deciduous trees. All of them were detected on *Quercus robur* L. in the photosynthesising myco-horizon: *Cylindrobasidium evolvens* (Fr.) Jülich (one finding on undergrowth), *Peniophora quercina* (Pers.) Cooke (I – II Kraft classes, II – III state categories) and *Vuilleminia comedens* (Nees) Maire (I – II, IV Kraft classes, I – III state categories) (Appendix 1, 2). The analysis of the health conditions of *Quercus robur* L. showed that the trees in I ($I = 1.38$; 54.5%) and II ($I = 2.15$; 27.3%) state categories were most frequent at this EP. Only 4.3% of trees were wilting. The artificial plantings of *Pinus sylvestris* L., regardless of age, do not ensure the viable stand state: 21.5% of pine trees were healthy ($I = 1.40$), weakened ones – 27.1% ($I = 2.35$), heavily weakened – 40.9% ($I = 2.90$), wilting – 10.5% ($I = 2.90$). Recently dead stands and old dead-wood were absent. From the point of tree development, trees were their divided into individual categories as follows: 65.3% – I Kraft class trees, 22.2% – II Kraft class trees, 9.3% – III Kraft class trees, 2.8% – Kraft class trees. We did not detect xylophagous fungi on *Pinus sylvestris* L.

3.3.3 Holosshyivs'kyy Park name Maksyma Ryl's'koho

EP3 (0.7 ha) was located in the Holosshyivs'kyy Park of Maksyma Ryl's'koho in the valley of the river Horikhuvatka. The relief was heavily dissected. The stand consisted of one storey of *Quercus robur* L. ($A = 60 - 80$). The canopy cover was 0.6 – 0.7, $G_n = 240.4 \text{ m}^2 \text{ ha}^{-1}$, $N = 247 \text{ psc. ha}^{-1}$; $H_{\text{ave}} = 18.4 \text{ m}$, $H_{\text{min}} = 15.1 \text{ m}$, $H_{\text{max}} = 20.3 \text{ m}$, $S.D. = 1.92 \text{ m}$; $D_{\text{ave}} = 56.1 \text{ cm}$, $D_{\text{min}} = 34.2 \text{ cm}$, $D_{\text{max}} = 89.2 \text{ cm}$, $S.D. = 10.11 \text{ cm}$. The mechanical damage (average area of 0.51 cm²) was observed only on one tree. The undergrowth of *Quercus robur* L. was scarce.

The projected cover of the herbaceous storey was 75.0% (*Ambrosia artemisiifolia* L., *Capsela bursa-pastoris* L., *Dactylis glomerata* L., *Elytrigia repens* L., *Poa annua* L. and others).

The soil surface was in III stage of degradation: damaged areas occupied 15.5% of the total area. 5th and 6th categories of the soil surface state were absent. The clogging of the soil's surface was about 0.025%. The overall stage of recreational transformation was III.

At EP3 we detected the maximum number of wood-destroying fungi in the studied parks: 11 species (51 findings) represented 10 genera, 9 families, 5 orders. 76.5% of findings of wood-destroying fungi trophes of II rank on deciduous trees: *Basidiaradulum radula* (Fr.) Nobles, *Cylindrobasidium evolvens* (Fr.) Jülich, *Hyphodontia sambuci* (Pers.) J. Erikss., *Peniophora quercina* (Pers.) Cooke, *Phellinus robustus* (P. Karst.) Bourdot et Galzin, *Radulomyces molaris* (Chaillat ex Fr.) Christ., *Trichaptum bifforme* (Fr.) Ryvardeen and *Vuilleminia comedens* (Nees) Maire; 23.5% – eurytrophes of I rank: *Corticium roseum* Pers., *Ganoderma lucidum* (Curtis) P. Karst. and *Phellinus ferruginosus* (Schad.) Pat. (Appendix 1). It is not easy to delimit the borders between biotrophy, necrotrophy, and saprotrophy for wood-destroying fungi (Urchenko 2006). We detected only one biotrophic species – *Phellinus robustus* (P. Karst.) Bourdot et Galzin. Their frequency at EP3 was 2.0% (in the cavities of living trees of III state category).

The shares of wood-destroying fungi in different substrate categories showed that an equal distribution of species and findings of fungi was detected on fallen woody debris (7 species, 29 findings) and on living trees in I–IV state categories (6 species, 21 findings). No wood-destroying fungi were detected on stumps ($D_{ave} = 38.3$ cm, $H_{ave} = 0.1$ m).

The analysis of the vitality of *Quercus robur* L. revealed that wood-destroying fungi occurred mainly on *Quercus robur* L. trees of I (57.4%, findings; 53.2%, trees) and II (29.8%, findings; 30.4% trees) Kraft classes. WAKC of healthy (I state category) and weakened (II state category) trees indicate that the number of trees in Kraft classes I–II increases when the trees are closer to roads and open landscape elements. The total proportion of heavily weakened trees was high (26.6%) as well as the number of trees in the weakened Kraft class III. Only 19.0% of *Quercus robur* L. trees at EP3 were healthy, the rest were weakened to different extent due to the recreational impact. The analysis of the health conditions of *Quercus robur* L. revealed that the maximum number of xylophages was recorded on *Quercus robur* L. trees of II (38.3%) and III (31.9%) state categories. No wood-destroying fungi were detected on trees of V state category. Approximately one half of the identified xylophagous fungi (53.0%) occurred in the ground myco-horizon, and 39.2% in the photosynthesising myco-horizon of *Quercus robur* L. (Appendix 2).

3.3.4 Park “Syrets’kyy hay”

EP4 was located on the Park “Syrets’kyy hay”. The stand was two-storeyed with the first storey composed of *Quercus robur* L. (A = 60 – 80), and the second storey composed of *Carpinus betulus* L. (A = 60 – 80), *Acer platanoides* L. (A = 40 – 60) and *Tilia cordata* Mill. (A = 60 – 80); the canopy cover was 0.5 – 0.6. The stand parameters of *Quercus robur* L. were: $G_n = 94.4$ m² ha⁻¹; $N = 125$ psc. ha⁻¹; $H_{ave} = 23.2$ m,

$H_{min} = 21.9$ m, $H_{max} = 25.7$ m, S.D. = 1.98 m; $D_{ave} = 71.3$ cm; $D_{min} = 62.5$ cm, $D_{max} = 82.1$ cm, S.D. = 6.23 cm. The stand parameters of *Carpinus betulus* L. were: $G_n = 86.5$ m² ha⁻¹; $N = 265$ psc. ha⁻¹; $H_{ave} = 18.1$ m, $H_{min} = 16.2$ m, $H_{max} = 20.3$ m, S.D. = 1.34 m; $D_{ave} = 36.0$ cm; $D_{min} = 30.1$ cm, $D_{max} = 43.5$ cm, S.D. = 3.89 cm. *Acer platanoides* L.: $G_n = 21.8$ m² ha⁻¹; $N = 76$ psc. ha⁻¹; $H_{ave} = 16.9$ m, $H_{min} = 13.7$ m, $H_{max} = 19.2$ m, S.D. = 1.74 m; $D_{ave} = 19.5$ cm; $D_{min} = 16.3$ cm, $D_{max} = 24.7$ cm, S.D. = 2.51 cm. Biogroups of *Tilia cordata* Mill. were scattered and had the following inventory parameters: $G_n = 11.1$ m² ha⁻¹; $N = 28$ psc. ha⁻¹; $H_{ave} = 19.0$ m, $H_{min} = 16.4$ m, $H_{max} = 22.8$ m, S.D. = 1.92 m; $D_{ave} = 45.3$ cm; $D_{min} = 40.1$ cm, $D_{max} = 52.0$ cm, S.D. = 3.70 cm. Mechanically damaged trees (5.5%, an average area of 95.6 cm²) were recorded at EP4. The undergrowth was composed only of *Acer platanoides* L.

The recreational transformation was more intense at EP4 in comparison with the previous experimental plots EP1 – EP3. The projected cover of the herbaceous storey was 73.0%. The dominant species at EP4 were *Galinsoga ciliata* (Raf.) Blake, *Geum urbanum* L., *Impatiens parviflora* L., *Solidago virgáurea* L., *Urtica dioica* L., *Geranium sylvaticum* L.

The soil surface was in III stage of degradation: damaged areas occupied 21.3%, while 16.5% of the damaged areas were in 3th and 4th state categories of the soil surface degradation. The clogging of the soil's surface was about 0.05%. Overall, the plots was assigned III stage of the recreational transformation.

Altogether 9 species (25, findings) of macromycetes were found at EP4, the fruiting of which occurs autumn. These fungi species represented 8 genera, 8 families, 5 orders. 48.0% of findings of xylophagous fungi were eurytrophes of II rank on deciduous trees: *Peniophora quercina* (Pers.) Cooke, *Phellinus robustus* (P. Karst.) Bourdot et Galzin, *Phlebia radiata* Fr., *Stereum hirsutum* (Willd.) Pers. and *Vuilleminia comedens* (Nees) Maire. The same percentage, i.e. 48.0% of findings of xylophagous fungi were eurytrophes of I rank: *Hypholoma fasciculare* (Huds.) P. Kumm., *Schizophora paradoxa* (Schrad.) Donk and *Schizophyllum commune* Fr. Stenotrophes (4.0%, findings) were represented by *Peniophora rufomarginata* (Pers.) Bourdot et Galzin (Appendix 1). The frequency of biotrophic species *Phellinus robustus* (P. Karst.) Bourdot et Galzin at EP4 was 2.5%.

It is also clear that the composition and distribution of xylophagous fungi is tightly connected not only with vitality and health conditions of tree stands, but also with the myco-horizons and the substrate type. From this point of view, the greatest number of the identified xylophagous fungi (60.0%) was found in the photosynthesising myco-horizon and 20.0% in the stem myco-horizon. 16.0% of wood-destroying fungi were in the ground myco-horizon, 4.0% in the stem base myco-horizon (Appendix 2). On *Quercus robur* L., we detected 4 species (8 findings) of xylophagous fungi. *Phellinus robustus* (P. Karst.) Bourdot et Galzin (37.5% of findings) preferred broken bark and branches. The occurrence of *Peniophora quercina* (Pers.) Cooke (25.0%) and *Vuilleminia comedens* (Nees) Maire (25.0%) was mostly limited to the top of branches in the canopy ($D_{min} = 0.8$ cm, $D_{max} = 5.5$ cm). *Schizophyllum commune* Fr. was the saprotroph occurring on fallen branches (12.5%, $D = 15.5$ cm).

The analysis of the vitality of *Quercus robur* L. revealed that wood-destroying fungi were observed mainly on trees of I Kraft class (77.5% findings), while their proportion on trees of II Kraft class was lower (12.5%). The trees of III (4.7%) and IV (5.3%) Kraft classes did not have a mycological component. Such a distribution of trees in Kraft classes is caused by the age structure of *Quercus robur* L. The analysis of the health conditions of *Quercus robur* L. and the species composition of xylotrophic fungi showed that the greatest number of xylotrophs (87.5%) was observed on the trees of II state category (78.6%, $I = 1.56$). The smallest number of xylotrophs (12.5%) was recorded on the trees of I state category (7.1%, $I = 1.46$). No wood-destroying fungi were observed on the heavily weakened (7.1%) and the wilting trees (7.1%).

On *Carpinus betulus* L. we detected 5 species (13 findings) of xylotrophic fungi: *Schizopora paradoxa* (Schrad.) Donk (53.8% of findings) was mostly limited to broken branches in canopy ($D_{ave} = 12.0$ cm), *Vuilleminia comedens* (Nees) Maire was particularly common at top of the branches of living trees (23.1%, $D_{ave} = 2.0$ cm). *Hypholoma fasciculare* (Huds.) P. Kumm. (on stem base), *Phlebia radiata* Fr. (on stem bark) and *Stereum hirsutum* (Willd.) Pers. (in the photosynthesising myco-horizon) were detected on a single deadwood piece. The analysis of vitality of *Carpinus betulus* L. revealed that a half of the observations of xylotrophic fungi (46.2%) was detected on trees in III Kraft development class (with 30.0% frequency at the plot). The analysis of the health conditions of *Carpinus betulus* L. and species composition of xylotrophic fungi showed that the greatest number of xylotrophs (41.7% of findings) occurred on the trees of III (24.0% frequency at the plot, $I = 2.79$) and IV (12.0%, $I = 3.77$) state categories. This is understandable since these categories of trees have the highest probability to be damaged by plant pathogens and are least resistant to other negative factors. No wood-destroying fungi were detected on the healthy trees (20.0%).

The plantings of *Acer platanoides* L. and *Tilia cordata* Mill. were weakened ($I = 1.57$, $I = 1.65$), but the weighted average of Kraft classes was optimum (2.6; 2.4). There was no V state category of *Acer platanoides* L. at the experimental plot. No wood-destroying fungi were detected on *Acer platanoides* L. We recorded 2 findings of *Peniophora rufomarginata* (Pers.) Bourdot et Galzin at the ends of the branches of living trees of *Tilia cordata* Mill. (heavily weakened, III Kraft class, photosynthesising myco-horizon).

3.3.5 Solom'yansky Landscape Park

EP5 (0.5 ha) was located in the valley of the river Mokra of tract "Kuchmyr Yar". The stand consisted of two storeys. The first storey composed of *Quercus robur* L. ($A = 40 - 60$) and *Q. rubra* L. ($A = 20 - 40$). The second storey consisted of *Acer platanoides* L. and *Tilia cordata* Mill. The canopy cover was 0.4 – 0.5. *Quercus robur* L.: $G_n = 104.8$ m² ha⁻¹, $N = 170$ pcs. ha⁻¹, $H_{ave} = 16.1$ m, $H_{min} = 14.3$ m, $H_{max} = 17.9$ m, S.D. = 1.81 m; $D_{ave} = 36.7$ cm; $D_{min} = 29.1$ cm, $D_{max} = 46.3$ cm, S.D. = 8.62 cm. *Quercus rubra* L.: $G_n = 80.1$ m² ha⁻¹, $N = 103$ pcs. ha⁻¹, $H_{ave} = 17.1$ m, $H_{min} = 14.9$ m, $H_{max} = 19.1$ m, S.D. = 1.72 m; $D_{ave} = 22.0$ cm; $D_{min} =$

18.1 cm, $D_{max} = 31.3$ cm, S.D. = 4.93 cm. Mechanical damage was observed especially on *Quercus robur* L. (9.8%, average area of 187.7 cm²). Stand parameters for *Tilia cordata* Mill. ($A = 40 - 60$) were as follows: $G_n = 29.6$ m² ha⁻¹, $N = 86$ pcs. ha⁻¹, $H_{ave} = 14.0$ m, $H_{min} = 12.4$ m, $H_{max} = 16.1$ m, S.D. = 1.43 m; $D_{ave} = 22.1$ cm, $D_{min} = 18.1$ cm, $D_{max} = 29.3$ cm, S.D. = 7.35 cm. *Acer platanoides* L. ($I = 2.25$) occurred in undergrowth.

The total projected cover of herbaceous storey was 55.5%. *Dactylis glomerata* L., *Senecio vulgaris* L. *Phalacrolooma annuum* L. and *Urtica dioica* L. dominated this storey. The leaf-litter has begun to deteriorate. The soil surface was in IV stage of degradation: damaged areas occupied 28.0% of the total area, out of which 25.5% were in 3rd, 4th, 5th and 6th categories of the soil surface state. The clogging of the soil's surface was less than 0.08%. The overall stage of recreational transformation was IV.

Xylotrophic fungi were presented by 6 species, 5 genera, 5 families, 4 orders. 69.2% of findings of xylotrophic fungi were eurytrophes of II rank on deciduous trees: *Peniophora quercina* (Pers.) Cooke, *Radulomyces molaris* (Chaillat ex Fr.) Christ., *Stereum hirsutum* (Willd.) Pers. and *Vuilleminia comedens* (Nees) Maire. Stenotrophes (19.3% of findings) were represented by only one species: *Peniophora rufomarginata* (Pers.) Bourdot et Galzin. Eurytrophes of I rank (11.5%, findings) were also represented by one species: *Schizopora paradoxa* (Schrad.) Donk (Appendix 1). The shares of wood-destroying fungi in different substrate categories showed that species and findings were confined to trees in I – IV state categories. The greatest number of the identified wood-destroying fungi (96.2% of findings) occurred in the photosynthesising myco-horizon and 3.8% in the stem base myco-horizon (Appendix 2).

On *Quercus* spp. we detected 5 species of xylotrophic fungi, namely *Peniophora quercina* (Pers.) Cooke, *Radulomyces molaris* (Chaillat ex Fr.) Christ., *Schizopora paradoxa* (Schrad.) Donk, *Stereum hirsutum* (Willd.) Pers., *Vuilleminia comedens* (Nees) Maire, on *Quercus robur* L., and one finding of *Vuilleminia comedens* (Nees) Maire was also recorded on *Quercus rubra* L. (I state category, I Kraft class). Trees of *Quercus robur* L. were heavily weakened ($I = 2.75$). The greatest number of findings of fungi (63.2%) was observed on *Quercus robur* L. trees of III state category. No wood-destroying fungi were detected on healthy trees and fresh deadwood. The analysis of the vitality of *Quercus robur* L. revealed that 52.6% of the findings of fungi were confined to the highest Kraft class, and the smallest number of findings to IV, V Kraft classes.

There were no healthy and weakened trees of *Tilia cordata* Mill. at EP5 ($I = 3.75$). We detected 5 findings of *Peniophora rufomarginata* (Pers.) Bourdot et Galzin on trees of III – IV Kraft classes and III – IV state category. No wood-destroying fungi were detected on *Acer platanoides* L., *Fraxinus excelsior* L. and *Populus tremula* L. The analysis of myco-horizons showed that most findings of xylotrophs (96.2%) were confined to the photosynthesising myco-horizon, and one finding of *Stereum hirsutum* (Willd.) Pers. was detected on the stem base of *Quercus robur* L.

3.3.6 Forest Park “Urochyshe Sovky”

EP6 (0.6 ha) was located in the Forest Park “Urochyshe Sovky” on the right bank of the river Dnipro. The stand was two-storeyed, the canopy cover was 0.4–0.5. The first storey was composed of *Pinus sylvestris* L. ($A = 40 - 60$; $G_n = 112.5 \text{ m}^2 \text{ ha}^{-1}$, $N = 220 \text{ pcs ha}^{-1}$; $H_{\text{ave}} = 21.9 \text{ m}$, $H_{\text{min}} = 18.1 \text{ m}$, $H_{\text{max}} = 24.5 \text{ m}$, S.D. = 2.90 m; $D_{\text{ave}} = 32.3 \text{ cm}$, $D_{\text{min}} = 28.5 \text{ cm}$, $D_{\text{max}} = 45.3 \text{ cm}$, S.D. = 5.91 cm.), and the second storey was composed of *Quercus robur* L. ($A = 40 - 60$; $G_n = 64.1 \text{ m}^2 \text{ ha}^{-1}$, $N = 220 \text{ pcs ha}^{-1}$; $H_{\text{ave}} = 18.9 \text{ m}$, $H_{\text{min}} = 15.1 \text{ m}$, $H_{\text{max}} = 20.3 \text{ m}$, S.D. = 2.16 m; $D_{\text{ave}} = 23.4 \text{ cm}$, $D_{\text{min}} = 17.9 \text{ cm}$, $D_{\text{max}} = 35.8 \text{ cm}$, S.D. = 7.02 cm). The average area of the mechanical damage of *Pinus sylvestris* L. trees exceeded 178 cm^2 (2.7% of trees), and of *Quercus robur* L. – 123 cm^2 (9.1% of trees). The undergrowth was formed by *Fraxinus excelsior* L. ($I = 2.60$) and *Quercus robur* L. ($I = 2.45$). The understory was formed by *Frangula alnus* Mill. (findings of *Schizopora paradoxa* (Schr.) Donk, *Chondrostereum purpureum* (Pers.) Pouzar) and *Sambucus nigra* L. (findings of *Hyphodontia sambuci* (Pers.) J. Erikss.).

The projected cover of the herbaceous storey was 50.5%, the clogging of the soil’s surface was 0.15%. *Chelidonium majus* L., *Dactylis glomerata* L., *Impatiens parviflora* L., *Stenactis annua* L. dominated in the herbaceous storey. The soil surface was in V stage of degradation: damaged areas occupied 35.3% of the total area, out of which 3rd, 4th and 5th categories of the soil surface state constituted 26.1%. The overall stage of recreational transformation was IV.

We detected 8 species of wood-destroying fungi from 7 genera, 7 families and 5 orders. 73.3% of findings of xylo-trophic fungi were eurytrophes of II rank on deciduous trees: *Chondrostereum purpureum* (Pers.) Pouzar, *Hymenochaete rubiginosa* (Dicks.) Lév., *Hyphodontia sambuci* (Pers.) J. Erikss. and *Vuilleminia comedens* (Nees) Maire. 20.0% of findings of xylo-trophic fungi were eurytrophes of I rank: *Coniophora arida* (Fr.) P. Karst., *Schizopora flavipora* (Berk. et M. A. Curtis ex Cooke) Ryvarden and *Schizopora paradoxa* (Schr.) Donk. Eurytrophes of II rank on coniferous trees (6.7%, findings) was represented by only one species: *Trichaptum hollii* (J.C. Schmidt) Kreisel (Appendix 1). 50.0% of findings of fungi at EP6 were confined to stem base myco-horizon, while in stem and photosynthesising myco-horizons we detected the same number of wood-destroying fungi (20.0%) (Appendix 2). 3 species of wood-destroying fungi were recorded on *Quercus robur* L. – *Hymenochaete rubiginosa* (Dicks.) Lév., *Schizopora flavipora* (Berk. et M. A. Curtis ex Cooke) Ryvarden and *Vuilleminia comedens* (Nees) Maire. The greatest number of the findings of fungi (57.1%) was recorded on trees of I state category (8.4% of total trees). The analysis of the vitality of *Quercus robur* L. showed that a half of the findings of fungi were recorded on trees of III Kraft class (42.9%). The investigated stands of *Quercus robur* L. were heavily weakened ($I = 3.01$) similarly as *Quercus robur* L. at EP5. The distribution of xylo-trophs in the myco-horizons of *Quercus robur* L. was as follows: 85.7% of xylo-trophic fungi were in the photosynthesising myco-horizon, 14.3% at the stem base end.

The analysis of the health conditions of *Pinus sylvestris* L. revealed that the stands were weakened ($I = 2.15$).

The proportion of healthy trees was below 2.0%, of weakened trees was 33.3%, heavily weakened – 36.5%. 79.3% of trees belonged to I Kraft class, and 15.9% trees to II Kraft class. Trees of IV and V Kraft classes were absent. At this EP we recorded *Coniophora arida* (Fr.) P. Karst. and *Trichaptum hollii* (J.C. Schmidt) Kreisel (recently dead of *Pinus sylvestris* L., II Kraft class).

3.3.7 Park-monument of landscape art “Nyvky”

The study of the artificial phytocoenoses at EP7 was conducted in the park-monument of the landscape art “Nyvky”, which belongs to the nature reserve fund of Ukraine. This territory has the most signs of recreational transformation from the studied parks of Kyiv. The stand was two-storeyed, with the first storey composed of *Quercus robur* L., the second storey composed of *Acer platanoides* L., *Ulmus glabra* Huds. and *Aesculus hippocastanum* L. The canopy cover was 0.4–0.5. The stand parameters of *Quercus robur* L. were: $A = 60 - 80$; $G_n = 128.7 \text{ m}^2 \text{ ha}^{-1}$, $N = 190 \text{ pcs ha}^{-1}$; $H_{\text{ave}} = 26.2 \text{ m}$, $H_{\text{min}} = 19.5 \text{ m}$, $H_{\text{max}} = 28.1 \text{ m}$, S.D. = 2.87 m; $D_{\text{ave}} = 82.8 \text{ cm}$, $D_{\text{min}} = 78.2 \text{ cm}$, $D_{\text{max}} = 95.1 \text{ cm}$, S.D. = 10.20 cm. The stand parameters of *Acer platanoides* L. were: $A = 40 - 60$; $G_n = 98.7 \text{ m}^2 \text{ ha}^{-1}$; $N = 178 \text{ pcs ha}^{-1}$; $H_{\text{ave}} = 16.0 \text{ m}$, $H_{\text{min}} = 12.4 \text{ m}$, $H_{\text{max}} = 18.1 \text{ m}$, S.D. = 2.56 m; $D_{\text{ave}} = 31.1 \text{ cm}$; $D_{\text{min}} = 20.5 \text{ cm}$, $D_{\text{max}} = 46.1 \text{ cm}$, S.D. = 9.22 cm. The proportion of all woody species with mechanical damages amounted 19.5% (355 cm^2). The understory was absent. The leaf-litter is completely absent too.

The total projected cover of the herbaceous storey was 25.5%. The soil surface in V stage of degradation: damaged areas occupied 45.5% of the total area, out of which 37.1% were in 3rd, 4th, 5th and 6th categories of the soil surface state. The clogging of the soil’s surface was 0.20%. The plots was assigned the overall stage of recreational transformation of V.

In total, we detected 11 species of wood-destroying fungi from 10 genera, 8 families, and 4 orders. 74.1% of findings of xylo-trophic fungi were eurytrophes of II rank on deciduous trees: *Dendrothele acerina* (Pers.) P.A. Lemke, *Peniophora quercina* (Pers.) Cooke, *Phellinus robustus* (P. Karst.) Bourdot et Galzin, *Radulomyces molaris* (Chaillat ex Fr.) Christ., *Stereum hirsutum* (Willd.) Pers. and *Vuilleminia comedens* (Nees) Maire. 25.9% of findings of xylo-trophic fungi were eurytrophes of I rank: *Agaricus squarrosus* Oeder, *Armillaria mellea* (Vahl) P. Kumm., *Corticium roseum* Pers., *Phellinus ferruginosus* (Schad.) Pat. and *Schizopora paradoxa* (Schr.) Donk. The frequency of biotrophic species *Phellinus robustus* (P. Karst.) Bourdot et Galzin at EP7 was 0.7%. The greatest number of findings of fungi at EP7 (45.5%) occurred in the photosynthesising myco-horizon, while in the stem base and stem myco-horizons we detected the same number of wood-destroying fungi (18.2%). The minimum species (11.7%) and number of findings (3.9%) were detected in the stem base myco-horizon of *Aesculus hippocastanum* L. (Appendix 1, 2).

On *Quercus robur* L. we detected 8 species of xylo-trophic fungi: *Agaricus squarrosus* Oeder, *Phellinus ferruginosus* (Schad.) Pat., *Peniophora quercina* (Pers.) Cooke, *Phellinus robustus* (P. Karst.) Bourdot et Galzin, *Radulomyces*

molaris (Chaillat ex Fr.) Christ., *Stereum hirsutum* (Willd.) Pers., *Schizopora paradoxa* (Schrad.) Donk and *Vuilleminia comedens* (Nees) Maire. The analysis of vitality of *Quercus robur* L. revealed that all findings of fungi were recorded on trees belonging to I Kraft development class. The analysis of health conditions and species composition of wood-destroying fungi showed that the proportion of xylotrophic fungi was the same (33.3% of findings) in II (17.5%, trees) and III (32.5%, trees) state categories. There were no old dead stands of *Quercus robur* L. at EP7.

Only *Dendrothele acerina* (Pers.) P.A. Lemke and *Corticium roseum* Pers. developed on *Acer platanoides* L. 93.3% findings were detected in I state category (7.7%, $I = 1.44$) indicating that the development of the communities of *Acer platanoides* L. and wood-destroying fungi is not balanced. The analysis of the vitality of *Acer platanoides* L. showed that the proportion of xylotrophic fungi in I (31.0% of trees) and II (38.0% of trees) Kraft classes was the same (33.3% of findings). Only one species was detected on *Aesculus hippocastanum* L. (*Armillaria mellea* (Vahl) P. Kumm, wilting tree, I Kraft class, root myco-horizon). On *Ulmus glabra* Huds. ($I = 2.75$, I–II Kraft classes), wood-destroying fungi were absent.

3.4. Species richness of xylomycobiota

The analysis of species richness of wood-destroying fungi in the urban conditions of parks along the gradient of recreational transformation showed that the highest species richness was at EP4 and EP7 (the investigated stands were to 60–80% composed of *Quercus robur* L.). In general, species diversity of xylotrophic macromycetes at experimental plots caused by the occurrence of species that grow on different substrates: *Schizopora paradoxa* (Schrad.) Donk and *Stereum hirsutum* (Willd.) Pers. It is also associated with the development of stenotrophic fungi.

We take the xylomycocomplex of *Quercus robur* L. as an example, in which 110 mycological findings occurred, out of which 57.3% findings were stenotrophic fungi. These species developed only on *Quercus robur* L. trees. The value of Menhinik's Index is increases along the gradient of recreational transformation. No correlation was found between the level of recreational transformation and value of Shannon's Index. The assessment of the evenness of wood-destroying fungi showed that the value of Pielou's Index is increased along the gradient of recreational transformation (Fig. 3). The analysis of the occurrence of wood-destroying fungi on different substrates showed that 66.9% of the findings were recorded on living trees of *Quercus* spp. (I–IV categories of state), 31.12% – on minor and middle branches.

Most of the findings of wood-destroying fungi on *Acer platanoides* L. also occurred on living trees, but only on their undamaged parts. The findings of wood-destroying fungi on *Carpinus betulus* L. dominated on living trees (53.3%) and the findings on *Tilia cordata* Mill. occurred only on living trees (100%). Wood-destroying fungi on *Pinus sylvestris* L. were recorded only on old deadwood or debris. The distribution of wood-destroying fungi in the myco-horizons showed that the maximum number of findings was in the photosynthesising myco-horizon (90 findings), and the minimum in

the ground myco-horizon (1 finding of *Armillaria mellea* (Vahl) P. Kumm. on *Aesculus hippocastanum* L.). The analysis of the trophic composition of wood-destroying fungi at all EPs showed that the greatest number of eurytrophes of II rank on deciduous species (100.0%) was detected at EP1; eurytrophes of I rank (48.0%) – at EP4; eurytrophes of II rank on coniferous species (6.5%) were found only at EP6. The highest share of stenotrophes (63.0% of findings) was detected at EP7.

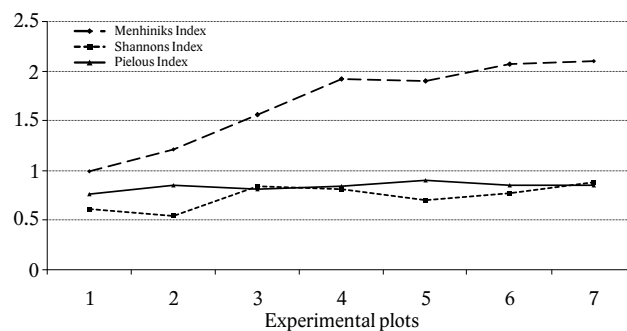

Fig. 3. Species richness of wood-destroying fungi in individual experimental plots.

3.5. Peculiarities of the studied communities

The analysis of the functioning and the development of communities between the established links in the studied parks. We constructed clusters on the base of the similarities between the individual data points using the Group Average clustering algorithm (Fig. 4). It is clear that the tree vegetation-fungi links of EP5, EP6 and EP7 are more similar one to another than to EP1-EP4. In addition, the tree vegetation-fungi links of EP1 and EP2 are more similar to each other. The obtained results need to be examined further to analyse the similarities of clusters, comparison of compositions of trees and fungi in the established communities in the parks in relation to the recreational transformation of environment in urban conditions.

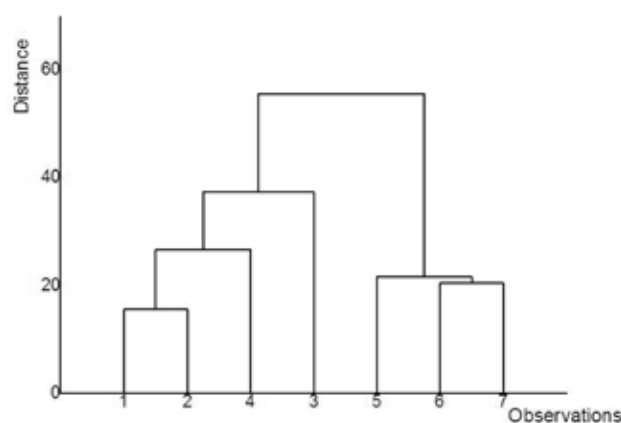

Fig. 4. Clustering Dendrogram of ecological links of parks (EP1–EP7).

PCA method was used to clarify the relationships between the compositions of trees and fungi. This method describes the variance in a dataset by linearly independent variables.

The direct dependence (in one quadrant) between the findings of xylotrophic fungi and the stand state index of woody plants was found, which is predictable for artificial phytocoenoses in urban conditions (Fig. 5). No direct dependence between the Kraft classes and the findings of xylotrophic fungi was revealed. The absence of such correlations can be explained by the differences in stand vitality between parks. The inverse relationship between the age and the morphometric parameters of woody plants is explained by biological peculiarities of trees.

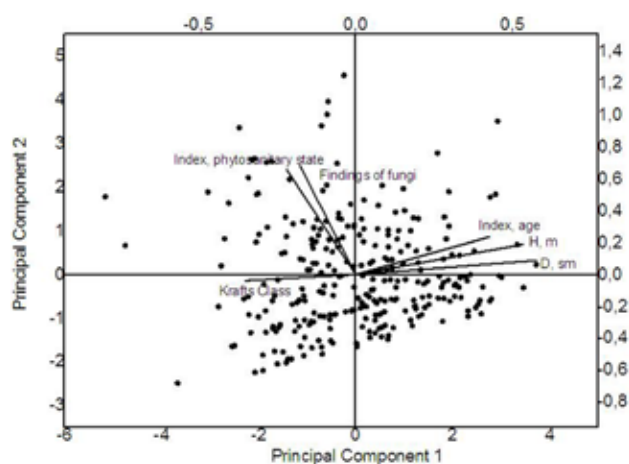

Fig. 5. Biplot of principal components by compositions of tree layer and findings of xylotrophic fungi.

4. Discussion

The relationship between the compositions of trees and fungi in urban conditions have long attracted the attention of scientists. The pioneering research by A. Shigo (1984) and his associates has produced a series of pictorial guidelines to improve the understanding of how trees respond to wounding and subsequent microbial infections that lead to wood decay.

The role of wood-destroying fungi as potential causes of stem breakage was shown on hazardous trees removed in the Megapolis (Helsinki City). The occurrence of the fungi was investigated in terms of frequency, visibility and as potential causes of stem breakage. Mechanical injuries, subsequent infections, and environmental changes are typical features of life for urban trees (Terho et al. 2007). Moreover, our results showed that the state of the communities between tree vegetation and xylotrophic fungi in urban conditions depends on the level of recreational transformation of the environment, particularly on the related changes in the structural and functional integrity of parks. The species richness of wood-destroying fungi in parks increases with the recreational transformation, which is evidenced by the values of Menhinik's Index and Pielou's Index.

The identification of common wood decay fungi associated with urban living trees is presented in the works of other authors (Dai et al. 2007). The connections between mechanical wood injuries, settlement of fungi and drying of trees; and the mechanisms of compartmentalisation are shown in these studies (Shigo 1984; Smith 2006; Shortle & Dudzik

2012). Our data on the changes in the conditions of woody plants due to transformation correspond with the results of other authors. The case study of the Kyiv City has shown that as the recreational transformation of parks increases, the interrelation of trophic, ecological and systematic compositions of xylotrophic fungi to vitality, age structure and health conditions of tree vegetation is lost.

The identification of the fungi responsible for the decay enhances both the prediction of the consequences of wood decay and the prescription of management options including tree pruning or removal. The Sudden Oak Death outbreak has drawn attention to hardwood tree species, particularly in urban forests (Glaeser & Smith 2010). Among broad-leaved tree vegetation the greatest number of findings of xylotrophs is detected on *Quercus* spp. Our results showed that health conditions of urban ecosystems with dominating woody species (*Quercus robur* L., *Q. rubra* L., *Carpinus betulus* L., *Pinus sylvestris* L., *Acer platanoides* L., *Aesculus hippocastanum* L., *Tilia cordata* Mill.) decrease from healthy to heavily weakened by level of recreational transformation of parks.

Woody species were categorised as resistant, moderately resistant, non-resistant and perishable for their non-resistance against wood-decaying fungi (Suprapti 2010). Our results showed that in the case of broad-leaved tree species, 60.1% of findings of wood-destroying fungi were detected on living trees of I–IV state categories. Xylophores on coniferous species were detected only on old deadwood.

Previous publications have shown the complexity of the interactions between trees, fungi and the environment from the macro to the micro level (Schwarze 2008). Our analysis of myco-horizons at macro level revealed that wood-destroying fungi develop more often in the photosynthesising myco-horizon, which is probably connected with the substantial transformation of other myco-horizons by recreants. The composition of xylophores changes also due to the species composition and the structure of the parks. It has been proved that the composition of xylophoric fungi in broad-leaved and coniferous artificial phytocoenoses is not balanced, as the dispersal of xylophoric fungi in them is limited by a lower quantity of available living and dead rooting substrate, by greater openness of stand canopy, by fewer protective properties of the herbaceous cover, and the degradation of the soil surface layer. This is in agreement with other studies, which presented the structures of pioneer fungi species in dead branches of various morphometric parameters (Rayner & Boddy 1987). The facultative species of xylophores with a high level of pathogenicity take an active part in the formation of the most durable forest ecosystems. The dispersal of xylophoric fungi in such phytocoenoses is limited by the amount of the available substrate and by extremely high evaporation that depends on the canopy openness and slight development of projective cover of herbaceous storey (Zmitrovich 1997). The differences in Fungal Community Ecology resulting from the presence of different species, interactions between spatial and temporal locations within wood species, and microclimatic variation are presented too (Boddy 2001).

Hence, the inter-links between tree vegetation and xylophoric fungi are significantly influenced by human activities.

Acknowledgement

This study was supported by the grant no. 011U005375 “Co-adaptive system of tree vegetation and xylotrophic fungi in natural forests and artificial phytocoenoses of Kyiv” (2013 – 2014) of the National Academy of Science of Ukraine. Assistance provided by Dr. Sci., Prof. Vladimir Radchenko was greatly appreciated.

References

- Arefyev, S., 2010: Systems analysis of biota of xylotrophic fungi. Novosibirsk, Nauka, 260 p.
- Bernicchia, A., Gorjón, S., 2010: Corticiaceae s.l. In: Fungi Europaei, 12. Italia, Ed. Candusso, 1008 p.
- Biluk, G., 1977: Geobotanical zoning of Ukraine. Kyiv, Naukova dumka, 301 p.
- Bondarceva, M., Parmasto, E., 1986: Identification guide to fungi of SSSR: Order Aphyllophorales. Iss. 1. Leningrad, Nauka, 192 p.
- Blinkova, O., Ivanenko, O., 2014: Co-adaptive tree vegetation system of wood-destroying (xylotrophic) fungi in artificial phytocoenoses, Ukraine. Lesnícky časopis – Forestry Journal, 60: 168–176.
- Boddy, L., 2001: Fungal community ecology and wood decomposition processes in angiosperms: from standing tree to complete decay of coarse woody debris. Ecological Bulletins, 49: 43–56.
- Cherepanov, S., 1995: Vascular Plants of Russia and Neighboring Countries. Saint Petersburg, World and family, 992 p.
- Cléménçon, H., 2009: Methods for working with macrofungi: Laboratory, cultivation and preparation of larger fungi for light microscopy. Eaching, IHW Verlag, 88 p.
- Dai, Y. C., Cui, B. K., Yuan, H. S., Li, B. D., 2007: Pathogenic wood-decaying fungi in China. Forest Pathology, 37: 105–120.
- Dilis, N., 1974: Program and methodology of biocenology research. Moscow, Nauka, 404 p.
- Eriksson, J., Hjorstam, K., Ryvarden, L., 1973–1988: The Corticiaceae of North Europe. Fungiflora, Vol. 1–8, 1631 p.
- Gavriluk, V., 1956: Nature of Kyiv City and the surrounding area: physical-geographical characteristics. Kyiv, Publisher Shevchenko University, 70 p.
- Glaeser, J. A.; Smith, K. T., 2010: Decay fungi associated with oaks and other hardwoods in the western United States. 6th Western Hazard Tree Workshop: 19–31.
- Kirk, P., Ansell, A., 1992: Authors of fungal names. A list of authors of scientific names of fungi, with recommended standard forms of their names, including abbreviation. Kew, Int. Myc. Inst., 95 p.
- Mc Neill, etc., 2011: International Code of Nomenclature for algae, fungi, and plants (Melbourne Code) adopted by the Eighteenth International Botanical Congress Melbourne, Australia, July 2011.
- Mirkin, B., Naumova, L., 1998: Science of vegetation. Ufa, Hilem, 413 p.
- Parmasto, E., Nilsson, H., Larsson, K.-H., 2009: Cortbase version 2.1. Extensive updates of a nomenclatural database for corticioid fungi (Hymenomycetes).
- Polyakov, A., 2009: Crime forest formations and their ecological role. Kharkiv, Nove slovo, 405 p.
- Rayner, A. D. M., Boddy, L., 1987: Population structure and the infection biology of wood-decay fungi in living trees. Adv. Plant Pathol., 107:143–154.
- Robert, V., Stegehuis, G., Stalpers, J., 2005: The MycoBank engine and related databases.
- Rusin, L., 2003: Monitoring of recreational forests. Moscow, RAN, 167 p.
- Rypáček, V., 1957: Biologie dřevokazných hub. Praha, Nakladatelství Československé akademie věd, 209 p.
- Sanitary Forest Regulation in Ukraine. 1995. Resolution of Government of Ukraine No 555 (27 July 1995). Kyiv, 20 p.
- Shigo, A., 1984: Compartmentalization: a conceptual framework for understanding how trees grow and defend themselves. Annual Review of Phytopathology, 22: 189–214.
- Schmidt, V., 1980: Statistical methods in comparative floristic. Leningrad, Publisher Leningrad University, 176 p.
- Schmidt, O., 2006: Wood and Tree Fungi. Biology, Damage, Protection, and Use. Heidelberg, Springer, 336 p.
- Schwarze, F.W.M.R., 2008. Diagnosis and prognosis of the development of wood decay in urban trees. Rowville, ENSPEC, 336 p.
- Shortle, W., Dudzik, K., 2012: Wood decay in living and dead trees: A pictorial overview. United State Forest Service, 26 pp.
- Smith, K., 2006: Compartmentalization today. Arboricultural Journal, 29: 173–184.
- Stepanova, N., Mykhin, V., 1979: Basis of ecology of wood-destroying fungi. Moscow, Nauka, 100 p.
- Suprapti, S., 2010: Decay resistance of Indonesian wood species against fungi. Journal of Tropical Forest Science, 22: 81–87.
- Terho, M., Hantula, J., Hallaakselä, A.-M., 2007: Occurrence and decay patterns of common wood-decay fungi in hazardous trees felled in the Helsinki City. Forest Pathology, 37: 420–432.
- Vasilevich, V., 1992: Biological diversity: approaches to the study and conservation. Saint Petersburg, Zin Ran, 232 p.
- Yurchenko, E., 2006: Natural substrata for corticioid fungi. Acta mycologica, 41: 113–124.
- Yurchenko, E., 2010: The genus *Peniophora* (Basidiomycota) of Eastern Europe. Morphology, taxonomy, ecology, distribution. Minsk, Belorusskaya nauka, 338 p.
- Zmitrovich, I., 1997: Distribution of the Aphyllophorales over territory St. Petersburg. Mycology and Phytopathology, 31: 19–27.

Appendix 1. Taxonomic and trophic compositions of xylotrophic fungi at all experimental plots.

Order	Family	Species	Trophic groups*
Corticiales	Corticiaceae	<i>Corticium roseum</i> Pers.	E1
		<i>Dendrothele acerina</i> (Pers.) P.A. Lemke	E2d
		<i>Vuilleminia comedens</i> (Nees) Maire	E2d
Hymenochaetales	Hymenochaetaceae	<i>Hymenochaete rubiginosa</i> (Dicks.) Lév.	E2d
		<i>Phellinus ferruginosus</i> (Schad.) Pat.	E1
		<i>P. robustus</i> (P. Karst.) Bourdot et Galzin	E2d
	Schizoporaceae	<i>Basidioradulum radula</i> (Fr.) Nobles	E2d
		<i>Schizopora flavipora</i> (Berk. et M.A. Curtis ex Cooke) Ryvar den	E1
		<i>S. paradoxa</i> (Schrad.) Donk	E1
Polyporales	Tubulicrinaceae	<i>Hyphodontia sambuci</i> (Pers.) J. Erikss.	E2d
	Ganodermataceae	<i>Ganoderma lucidum</i> (Curtis) P. Karst.	E1
		Meruliaceae	<i>Phlebia radiata</i> Fr.
	Polyporaceae	<i>Fomes fomentarius</i> (L.) Fr.	E2d
		<i>Trichaptum bifforme</i> (Fr.) Ryvar den	E2d
		<i>T. hollii</i> (J.C. Schmidt) Kreisel	E2c
	Russulales	Peniophoraceae	<i>Peniophora cinerea</i> (Pers.) Cooke
<i>P. quercina</i> (Pers.) Cooke			E2d
<i>P. rufomarginata</i> (Pers.) Bourdot et Galzin			S
Stereaceae		<i>Stereum hirsutum</i> (Willd.) Pers.	E2d
Agaricales		Agaricaceae	<i>Agaricus squarrosus</i> Oeder
	Cyphellaceae	<i>Chondrostereum purpureum</i> (Pers.) Pouzar	E2d
	Physalaciaceae	<i>Armillaria mellea</i> (Vahl) P. Kumm.	E1
		<i>Cylindrobasidium evolvens</i> (Fr.) Jülich	E2d
	Pterulaceae	<i>Radulomyces molaris</i> (Chaillet ex Fr.) Christ.	E2d
	Schizophyllaceae	<i>Schizophyllum commune</i> Fr.	E1
	Strophariaceae	<i>Hypholoma fasciculare</i> (Huds.) P. Kumm.	E1
Boletales	Coniophoraceae	<i>Coniophora arida</i> (Fr.) P. Karst.	E1

Note: *Eurytrophes of I rank (E1), eurytrophes of II rank on deciduous trees (E2d), eurytrophes of II rank on coniferous trees (E2c), stenotrophes (S).

Appendix 2. Distribution of xylotrophic fungi in myco-horizons at all experimental plots

No.	Fungi-consorts	Trees-edificators of consortium					Myco-horizons*				
		1	2	3	4	5	1	2	3	4	5
1	<i>Agaricus squarrosus</i> Oeder	—	—	1/5,6	—	—	—	—	—	—	—
2	<i>Armillaria mellea</i> (Vahl) P. Kumm.	1/100,0	—	—	—	—	—	—	—	—	
3	<i>Basidioradatum radula</i> (Fr.) Nobles	—	2/5,4	—	—	—	—	—	—	—	
4	<i>Chondrostereum purpureum</i> (Pers.) Pouzar	—	—	1/5,6	—	—	—	—	—	—	
5	<i>Coniophora arida</i> (Fr.) P. Karst.	—	—	1/5,6	—	—	—	—	—	—	
6	<i>Corticium roseum</i> Pers.	—	3/8,1	—	—	—	—	—	—	2/2,2	
7	<i>Cylindrobasidium evolvens</i> (Fr.) Jülich	—	—	—	—	—	—	—	—	2/2,2	
8	<i>Dendrothele acerina</i> (Pers.) P.A. Lemke	—	—	—	—	—	—	—	—	—	
9	<i>Fomes fomentarius</i> (L.) Fr.	—	—	8/44,4	6/35,3	—	—	—	—	—	
10	<i>Ganoderma lucidum</i> (Curtis) P. Karst.	—	—	1/5,6	—	—	—	—	—	—	
11	<i>Hyphodontia sambuci</i> (Pers.) J. Erikss.	—	—	1/5,6	—	—	—	—	—	—	
12	<i>Hypholoma fasciculare</i> (Huds.) P. Kumm.	—	—	2/11,1	2/11,8	—	—	—	—	—	
13	<i>Hymenochaete rubiginosa</i> (Dieks.) Lévl.	—	—	1/5,6	—	—	—	—	—	—	
14	<i>Peniophora cinerea</i> (Pers.) Cooke	—	—	1/5,6	—	—	—	—	—	—	
15	<i>P. quercina</i> (Pers.) Cooke	—	1/2,7	—	—	—	—	—	—	1/1,1	
16	<i>P. rutomarginata</i> (Pers.) Bourdot et Galzin	—	4/10,8	—	—	—	—	—	—	9/9,7	
17	<i>Phellinus ferruginosus</i> (Schad.) Pat.	—	—	—	—	—	—	—	—	11/11,8	
18	<i>P. robustus</i> (P. Karst.) Bourdot et Galzin	—	6/16,2	—	—	—	—	—	4/23,5	3/3,2	
19	<i>Phlebia radiata</i> Fr.	—	—	—	—	—	—	—	1/5,9	2/2,2	
20	<i>Radulomyces molaris</i> (Chaillat ex Fr.) Christ.	—	—	—	—	—	—	—	—	—	
21	<i>Schizopora flavipora</i> (Berk. et M.A. Curtis ex Cooke) Ryvarden	—	5/13,5	—	—	—	—	—	—	9/9,7	
22	<i>S. paradoxa</i> (Schrad.) Donk	—	—	—	—	—	—	—	—	1/1,1	
23	<i>Schizophyllum commune</i> Fr.	—	2/5,4	—	—	—	—	—	3/17,6	10/10,8	
24	<i>Stereum hirsutum</i> (Willd.) Pers.	—	—	—	—	—	—	—	—	—	
25	<i>Trichaptium bifforme</i> (Fr.) Ryvarden	—	1/2,7	—	—	—	—	—	1/5,6	4/4,3	
26	<i>T. hollii</i> (J.C. Schmidt) Kreisel	—	1/2,7	—	—	—	—	—	—	—	
27	<i>Vuilleminia comedens</i> (Nees) Maire	—	10/27,0	—	—	—	—	—	—	39/41,9	
All together species / findings:		1/1	12/37	10/18	6/17	37,0/10,8	22,2/10,2	44,4/22,3	44,4/56,0	44,4/56,0	
% of species / findings:		3,7/0,6	44,4/22,3	37,0/10,8	22,2/10,2	44,4/22,3	44,4/22,3	44,4/22,3	44,4/22,3	44,4/22,3	

Note: * - pcs.%; 1 – root; 2 – ground; 3 – stem base; 4 – stem; 5 – photosynthesising myco-horizon; “—” – not detected.